

# Hybrid controller for efficient AMD dual-plane CPU supply

The fastest solution to the new trend in computing power management

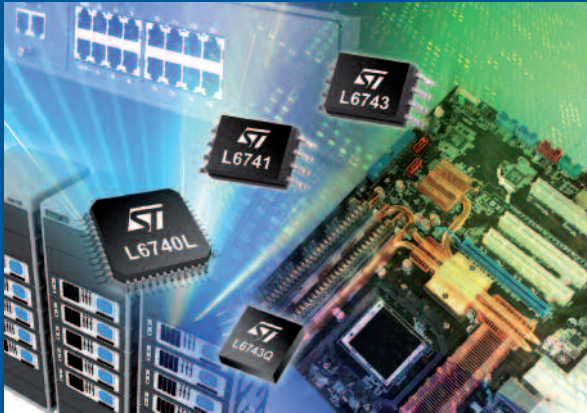

STMicroelectronics' L6740L, a dual-PWM multi-phase controller, is the first hybrid device designed for the power management needs of the new AMD desktop and server processors with PVI/SVI protocol and dual-plane supply.

New patent-pending PWM techniques and a full set of features that cover the CPU specifications and satisfy the new trend in power saving, make this device ideal for computing, datacom, telecom and storage markets.

The controller comes with a set of high-speed power MOSFET drivers for different design needs.

## Key features

- Compliant with AMD specifications for 0Fh and 10h family processors
- Automatic CPU-type detection
- Up to 4 phases for core section and 1 phase for north-bridge section
- Programmable PSI\_L management
- Dual-edge asynchronous scheme, with multichannel LTB Technology™
- Per-phase and average overcurrent protection
- Load monitor output
- Pre-bias startup
- Feedback-disconnect protection

## Main applications

- Voltage regulator for desktop PCs, IPCs, servers and workstations with AMD CPUs
- High-current voltage-regulator module

The L6740L embeds two independent controllers for the CPU core and the integrated north-bridge, each controller with its own set of protections. The device performs single-phase control for the NB section and up to 4-phase control for the core section. It features a dual-edge non-latched architecture, that allows fast load-transient response, so optimizing the output filter, and consequently reducing the total BOM cost. Further reduction is achieved using LTB (load transient boost) Technology (patent pending). Moreover, a power-saving technique greatly improves efficiency when the CPU is not fully operating, so providing full compliance with AMD specifications and facilitating motherboard compliance with the new environment-friendly standards.

The automatic CPU-type detection allows the design of flexible motherboards, able to receive directly all current and future CPUs for AM2 and F sockets. This is fundamental in the channel market, where the CPU can be changed by the final user, and its performances must still be supported.

Other features include overcurrent protection (average and per-phase for core section), load indicators, dual differential remote sensing, adjustable independent reference offset, feedback disconnection protection, programmable OV protection, switching frequency up to 1 MHz, LS-less startup to manage pre-biased output, flexible MOSFET driver support, V\_FIX mode for board debug, all in a simple HTQFP48 package.

The L6740L works with external power MOSFET drivers, to allow custom configurations with a reduced number of phases.

The L6741, L6743 and L6743Q are the new ST drivers, with standard pinout, embedded bootstrap diode, adaptive dead-time management and preliminary OV protection.

The SO8 package (L6741, L6743) offers application designers small size, low cost and easy reworkability. The tiny DFN10 3 x 3 mm package (L6743Q) is intended for space-constrained and thermally-enhanced solutions.

## AMD dual-plane CPU power supply

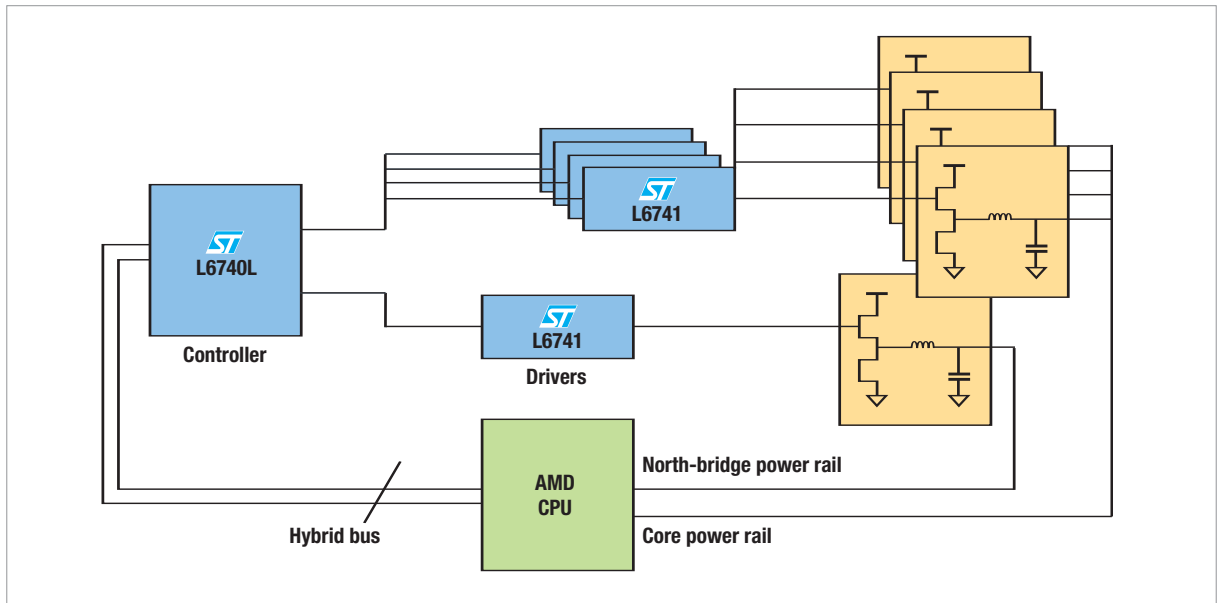

© STMicroelectronics - September 2007 - Printed in Italy - All rights reserved

The STMicroelectronics corporate logo is a registered trademark of the STMicroelectronics group of companies. All other names are the property of their respective owners.

For selected STMicroelectronics sales offices fax:

China +86 21 34054689; France +33 1 55489569; Germany +49 89 4605454; Italy +39 02 8250449; Japan +81 3 57838216; Singapore +65 6481 7771; Sweden +46 8 58774411; Switzerland +41 22 9292900; United Kingdom and Eire +44 1628 890391; USA +1 781 861 2678

Full product information at [www.st.com](http://www.st.com)

Order code: FLHYBRID0907

